

Wm. E. Williams No. 153F4AB Class 150 RF Angle Valve ASTM A 216 WCB (Aluminum Bronze Trim)

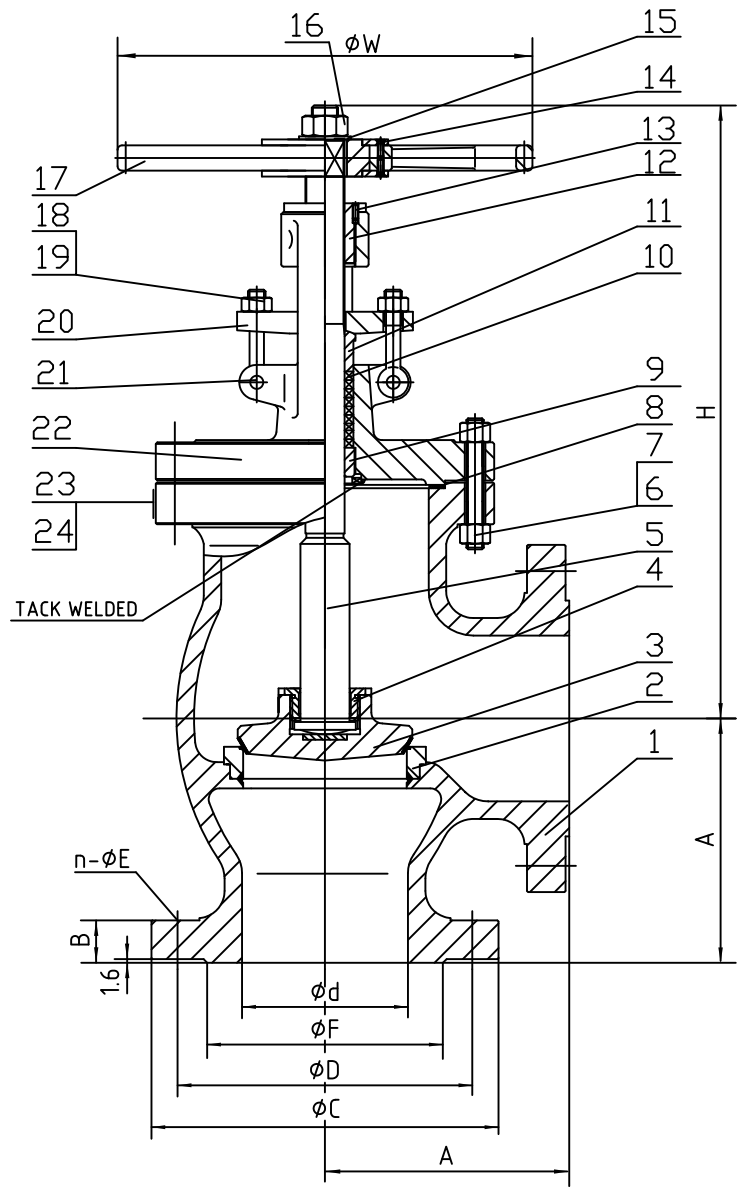

BILL OF MATERIALS

ITEM	PART	MATERIAL
1	BODY	ASTM A216-WCB
2	SEAT	ASTM A105+sCu6328
3	DISC	ASTM A105+EcuAl-A2
4	DISC COVER	ASTM A276-410
5	STEM	ASTM B148 C95500
6	BONNET BOLT	ASTM A193-B7
7	BONNET NUT	ASTM A194-2H
8	GASKET	SS304+GRAPHITE
9	BACKSEAT BUSHING	ASTM A276-410
10	PACKING RING	GRAPHITE
11	GLAND	ASTM A276-410
12	STEM NUT	ASTM A439 D-2
13	SCREW	ASTM A29-1035
14	SCREW	ASTM A29-1035
15	WASHER	ASTM A29-1035
16	HANDWHEEL NUT	ASTM A29-1035
17	HANDWHEEL	NODULAR CAST IRON
18	EYE BOLT	ASTM A193-B7
19	EYE BOLT NUT	ASTM A194-2H
20	GLAND FLANGE	ASTM A216-WCB
21	PIN	ASTM A29-1035
22	BONNET	ASTM A216-WCB
23	RIVET	304SS
24	NAMEPLATE	304SS

SIZE	d	A	B	C	D	n-φE	F	H	W
2"	51	101.5	16	152	120.5	4-19	92	323	200
2 1/2"	64	108	17.9	178	139.5	4-19	105	337	250
3"	76	121	20	190	152.5	4-19	127	350	250
4"	102	146	24.5	229	190.5	8-19	157	441	300
5"	127	177.8	24	255	216	8-22	186	460	350
6"	152	203.2	26	279	241.5	8-22	216	471	350
8"	203	247.65	29	343	298.5	8-22	270	542	450



TITLE: CAST STEEL ANGLE GLOBE VALVE
CLASS 150 - ALUMINUM BRONZE TRIM - B,B R,F

NO.	DATE	DESCRIPTION	PRP'D	REV'D	APP'D	DESIGNED	MARKING SYSTEM	MSS-SP-25	INSPECTION & TEST: API 598	MATERIAL: ASTM A216 GR.WCB	UNITS: Inch, mm
Δ	7/19/16	RELEASED	F.J.	R.P.	R.P.		DIM.OF FLANGE	ANSI B16.5	SHELL	HYDRO	450PSI
							CENTER TO FACE	ANSI B16.10	HPC SEAT	HYDRO	315PSI
Δ	6/12/15	RELEASED	F.J.	R.P.	R.P.		WALL THICKNESS	BS1873	BACK SEAT	HYDRO	315PSI
							DESIGNED	BS1873, ANSI B16.34			
									DATE: 06/12/15		SCALE: N.T.S.
									SIZE: 2" - 8"		FIG. No.: 153F-4AB
									DRAWN BY: F.J.		
									CHK'D & APR'D BY: R.P.	REV: 2	DWG No.: 60AN120143-28

Wm. E. Williams No. 153F4AB Class 150 RF Angle Valve ASTM A 216 WCB (Aluminum Bronze Trim)

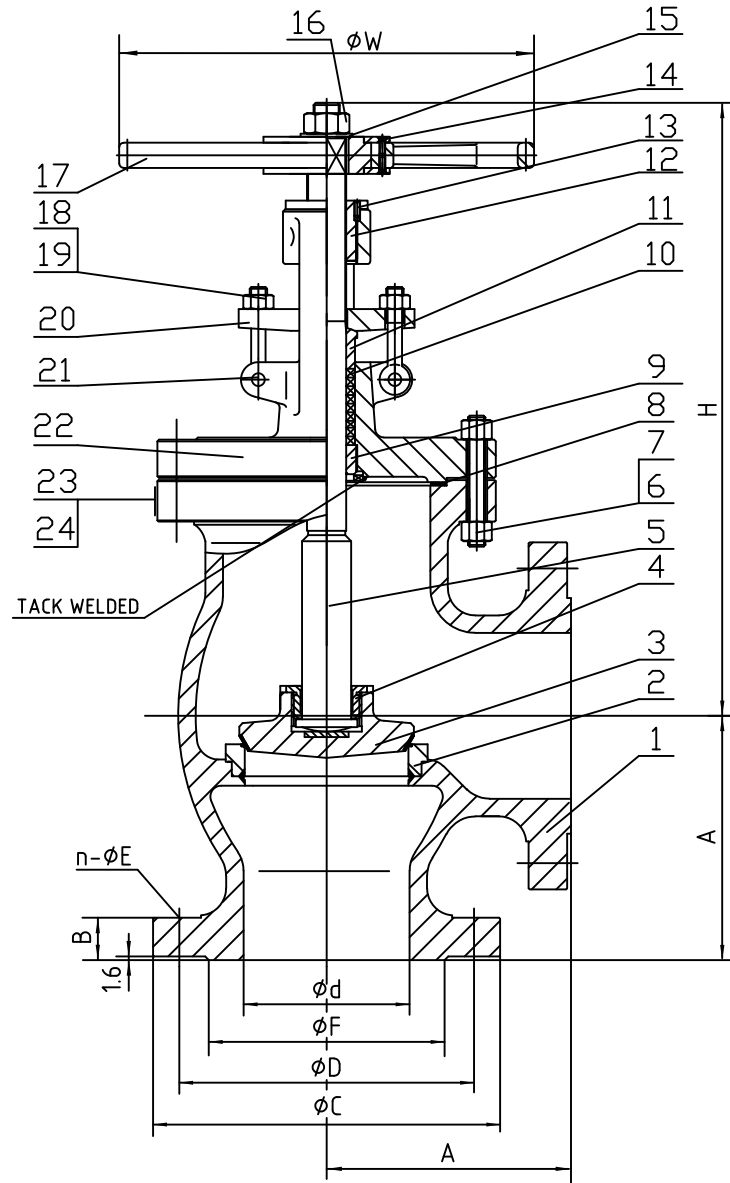

BILL OF MATERIALS

ITEM	PART	MATERIAL
1	BODY	ASTM A216-WCB
2	SEAT	ASTM A105+sCu6328
3	DISC	ASTM A105+EcuAl-A2
4	DISC COVER	ASTM A276-410
5	STEM	ASTM B148 C95500
6	BONNET BOLT	ASTM A193-B7
7	BONNET NUT	ASTM A194-2H
8	GASKET	SS304+GRAPHITE
9	BACKSEAT BUSHING	ASTM A276-410
10	PACKING RING	GRAPHITE
11	GLAND	ASTM A276-410
12	STEM NUT	ASTM A439 D-2
13	SCREW	ASTM A29-1035
14	SCREW	ASTM A29-1035
15	WASHER	ASTM A29-1035
16	HANDWHEEL NUT	ASTM A29-1035
17	HANDWHEEL	NODULAR CAST IRON
18	EYE BOLT	ASTM A193-B7
19	EYE BOLT NUT	ASTM A194-2H
20	GLAND FLANGE	ASTM A216-WCB
21	PIN	ASTM A29-1035
22	BONNET	ASTM A216-WCB
23	RIVET	304SS
24	NAMEPLATE	304SS

SIZE	d	A	B	C	D	n-phi E	F	H	W
10"	254	311.15	30	406	362	12-25	324	762	450

WILLIAM E. WILLIAMS VALVE CORPORATION
 38-52 REVIEW AVENUE LONG ISLAND CITY, NY 11101
 TEL: 718-392-1660 FAX: 718-729-5166

TITLE: CAST STEEL ANGLE GLOBE VALVE CLASS 150 - ALUMINUM BRONZE TRIM - B,B R,F

						MARKING SYSTEM	MSS-SP-25	INSPECTION & TEST: API 598	MATERIAL: ASTM A216 GR.WCB	UNITS: Inch, mm
	7/19/16	RELEASED	F.J.	R.P.	R.P.	DIM.OF FLANGE	ANSI B16.5	SHELL HYDRO 450PSI	CLASS: 150 DATE: 06/12/15	SCALE: N.T.S.
	6/12/15	RELEASED	F.J.	R.P.	R.P.	CENTER TO FACE	ANSI B16.10	HPC SEAT HYDRO 315PSI	SIZE: 10"	FIG. No.: 153F-4AB
						WALL THICKNESS	BS1873	BACK SEAT HYDRO 315PSI	DRAWN BY: F.J.	
NO.	DATE	DESCRIPTION	PRP'D	REV'D	APP'D	DESIGNED	BS1873, ANSI B16.34		CHK'D & APR'D BY: R.P.	REV: 2 DWG No.: 60AN120143-10-28