

William. E. Williams No.N15F2, N15F4, N15F4-AB Class 150 WCB, NRS Gate Valve ASTM A 216

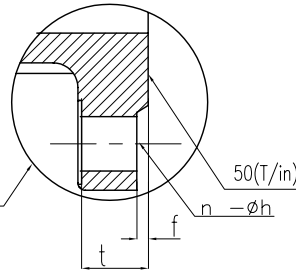
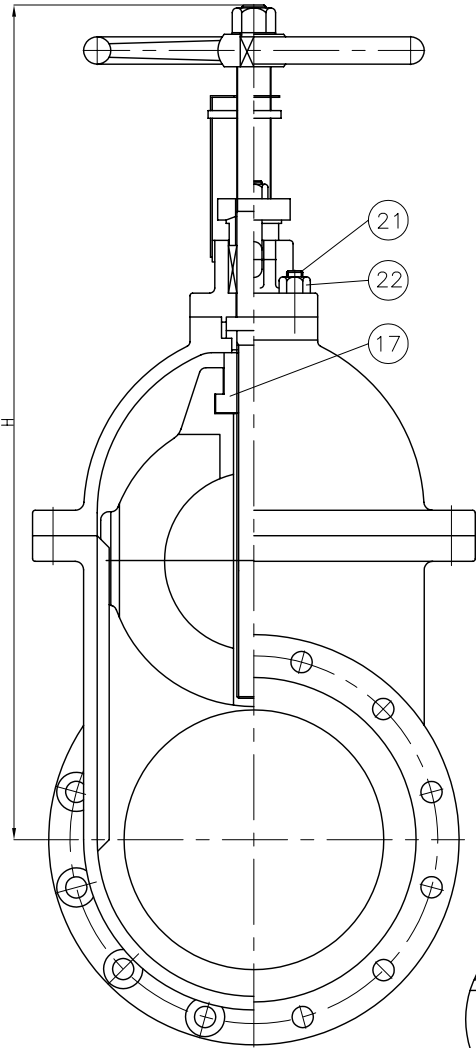
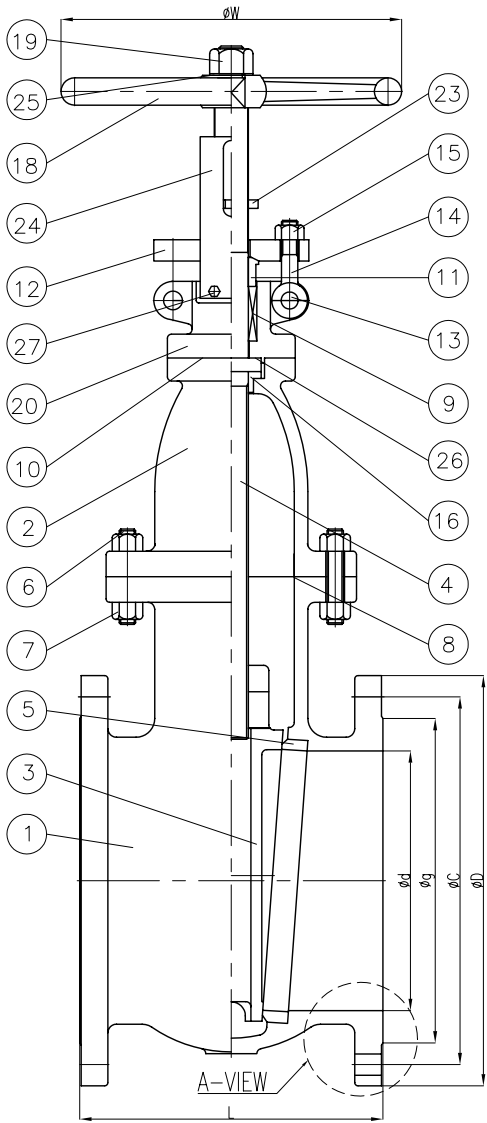

UNIT: Inch

SIZE	d	L	H	W	D	C	g	t	f	n-h
2.00	2.00	7.00	13.93	7.00	6.00	4.75	3.62	0.625	0.060	4-0.75
3.00	3.00	8.00	16.75	7.87	7.50	6.00	5.00	0.750	0.060	4-0.75
4.00	4.00	9.00	20.94	8.81	9.00	7.50	6.18	0.940	0.060	8-0.75
6.00	6.00	10.50	21.50	12.00	11.00	9.50	8.50	1.000	0.060	8-0.86
8.00	8.00	11.50	26.50	13.97	13.50	11.75	10.62	1.125	0.060	8-0.86
10.00	10.00	13.00	31.00	15.75	16.00	14.25	12.75	1.187	0.060	12-1.00
12.00	12.00	14.00	36.25	17.75	19.00	17.00	15.00	1.250	0.060	12-1.00
14.00	13.25	15.00	41.69	17.75	21.00	18.75	16.25	1.375	0.060	12-1.12
16.00	15.25	16.00	44.87	19.87	23.50	21.25	18.50	1.437	0.060	16-1.12

MARKING SYSTEM	MSS-SP-25	INSPECTION & TEST: API 598			
DIM.OF FLANGE	ANSI B16.5	SHELL	HYDRO	450PSI	
FACE TO FACE	ANSI B16.10	SEAT	AIR	80PSI	
WALL THICKNESS	API 600	BACK SEAT	HYDRO	315PSI	
OVERALL	API 600, ANSI B16.34				

BILL OF MATERIALS

NO.	PART NAME	N15F2	N15F4	NF15F4-AB	Q'TY
		API TRIM 8 (410/HF)	BRONZE TRIM	ALUM-BRZ TRIM	
1	BODY	A216Gr WCB	A216Gr WCB	A216Gr WCB	1
2	BONNET	A216Gr WCB	A216Gr WCB	A216Gr WCB	1
3	DISC	WCB 216 Co-CrA STEL. HF	WCB WITH BRONZE FACE	WCB W/B148 FACE	1
4	STEM	A479Gr 410 SS	ASTM B124	B148-C95500	1
5	SEAT RING	A105N WITH ASTM B62 FACE	A105 WITH ASTM B62 FACE	A105 W/B148 FACE	2
6	BONNET BOLT	A193Gr B7	A193Gr B7	A193Gr B7	1SET
7	BONNET NUT	A194Gr 2H	A194Gr 2H	A194Gr 2H	1SET
8	BONNET GASKET	P#1400G	P#1400G	P#1400G	1
9	PACKING	P#6610+P#6528	P#6610+P#6528	P#6610+P#6528	1SET
10	P/BOX GASKET	TBA#2100	TBA#2100	TBA#2100	1
11	GLAND RING	A479Gr 410	A479Gr 410	A479Gr 410	1
12	GLAND FLANGE	A105 or WCB	A105 or WCB	A105 or WCB	1
13	HINGE PIN	A105 or 410 SS	A105 or 410	A105	2
14	GLAND BOLT	A307Gr B	A307Gr B	A307Gr B	2
15	GLAND NUT	A307Gr B	A307Gr B	A307Gr B	2
16	THRUST BUSH	410 SS	ALUM-BRZ-B148	ALUM-BRZ-B148	1
17	STEM NUT	D42	BRONZE	ALUM-BRZ B148 C95500	1
18	HAND WHEEL	A197	A197	A197	1
19	HANDLE NUT	A307Gr B	A307Gr B	A307Gr B	1
20	PACKING BOX	A216Gr WCB	A216Gr WCB	A216Gr WCB	1
21	BOX BOLT	A307Gr B	A307Gr B	A307Gr B	4
22	BOX NUT	A307Gr B	A307Gr B	A307Gr B	4
23	INDICATOR	STEEL	STEEL	STEEL	2
24	INDICATOR PLATE	STEEL	STEEL	STEEL	1
25	HANDLE WASHER	STEEL	STEEL	STEEL	1
26	THRUST WASHER	410	ALUM-BRZ-B148	ALUM-BRZ-B148	1
27	PLATE BOLT	A307Gr B	A307Gr B	A307Gr B	2

NO.	DATE	DESCRIPTION	PRP'D	REV'D	APP'D
	10/06	AB TRIM			
TITLE NRS GATE VALVE CLASS 150					
SCALE	Fig #	DRAWING NO.			REV.
NONE	SEE ABOVE	38GA060299			0