

Wm. E. Williams No. 601W2 Class 600 BW Swing Check Valve ASTM A 216 WCB (API Trim 8)

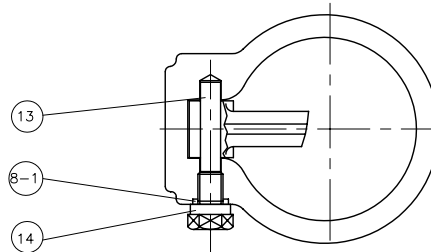
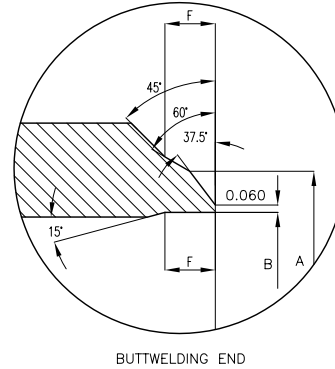
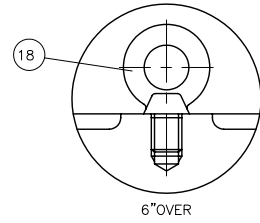
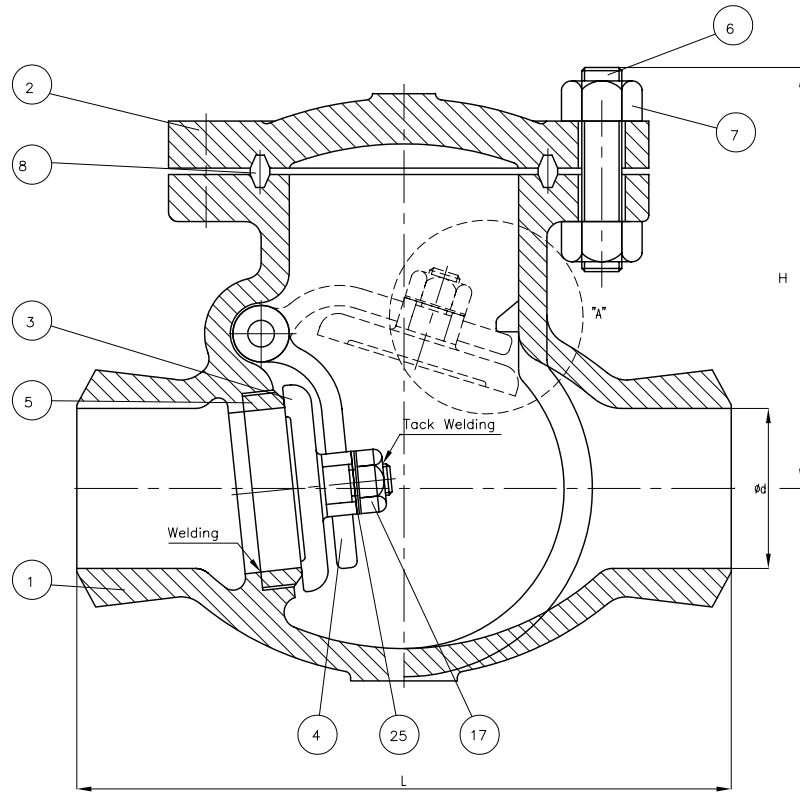

BILL OF MATERIALS				
NO.	PART NAME	MATERIALS	Q'TY	
1	BODY	A216Gr WCB	1	
2	COVER	A216Gr WCB	1	
3	DISC	6" & BELOW	A217Gr CA15	1
		8" & OVER	A216Gr WCB With 13Cr Welding	
4	ARM	A216Gr WCB	1	
5	SEAT RING	A105 With STELLITE Welding	1	
6	COVER BOLT	A193Gr B7	1SET	
7	COVER NUT	A194Gr 2H	1SET	
8	GASKET	P#1500	1	
8-1	PIN GASKET	P#1300	1	
13	HINGE PIN	A479Gr 410	1	
14	HINGE BOLT	A307Gr B	1	
17	DISC NUT	A194Gr 8	1	
18	EYE BOLT	A307Gr B	1	
25	WASHER	STEEL	1	

NOTE:

- SPECIFY PIPE SCHEDULE No. REQUIRED.
- TRIM #2, (API #8), OTHER TRIMS AVAILABLE

UNIT: INCH

SIZE	d	L	H	A	SCH-40		SCH-80	
					DIM-(B)	F	DIM-(B)	F
2.00	2.00	11.50	7.40	2.44	2.067	0.300	1.929	0.315
2.50	2.50	13.00	7.48	2.88	2.469	0.300	2.323	0.433
3.00	3.00	14.00	8.87	3.50	3.068	0.324	2.900	0.453
4.00	4.00	17.00	10.40	4.50	4.026	0.355	3.826	0.512
6.00	6.00	22.00	12.28	6.62	6.065	0.420	5.761	0.669
8.00	7.88	26.00	15.39	8.62	7.981	0.480	7.625	0.750
10.00	9.75	31.00	17.60	10.75	10.020	0.547	9.562	0.906
12.00	11.75	33.00	20.51	12.75	11.938	0.609	11.374	1.102
14.00	12.88	35.00	24.37	14.00	13.124	0.657	12.500	1.142
16.00	14.75	39.00	26.38	16.00	15.000	0.750	14.312	1.260
18.00	16.50	43.00	28.74	18.00	16.876	0.843	16.124	1.417
20.00	18.75	47.00	31.81	20.00	18.812	0.891	17.938	1.535
24.00	22.00	55.00	35.04	24.00	22.824	1.032	21.562	1.811

*Minimum Dimension

MARKING SYSTEM	MSS-SP-25	INSPECTION & TEST: API 598		
BUTTWELDING	ANSI B16.25	SHELL	HYDRO	2225PSI
FACE TO FACE	ANSI B16.10	SEAT	HYDRO	1650PSI
WALL THICKNESS	API 600	BACK SEAT	HYDRO	
OVERALL	API 600, ANSI B16.34			

ISSUED FOR PROPOSAL					
NO.	DATE	DESCRIPTION	PRP'D	REV'D	APP'D
WILLIAMS VALVE CORPORATION					
TITLE					
CAST STEEL SWING CHECK VALVE CLASS 600 B.C. BUTTWELDED END					
SCALE	Fig No.	DRAWING NO.			
NONE	601W2	60SC060145			
				REV.	0