

# Wm. E. Williams No. 602F2 Class 600 RF Globe Valve ASTM A 216 WCB (API Trim 8)

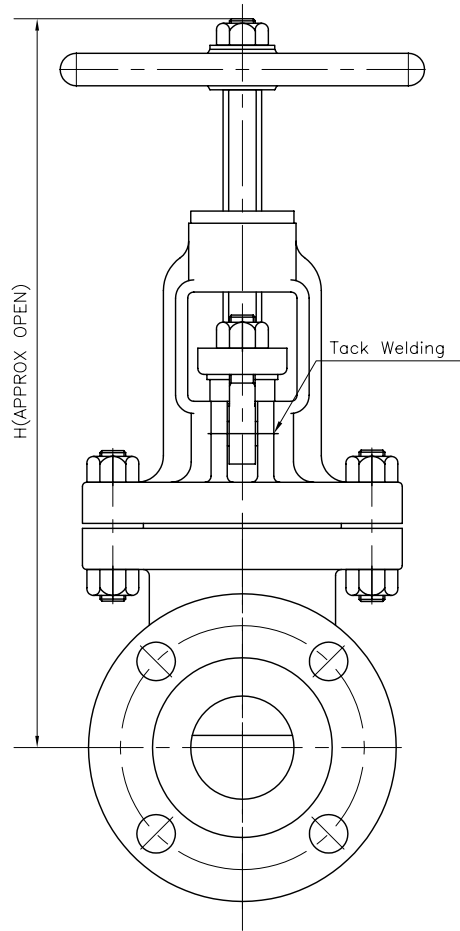
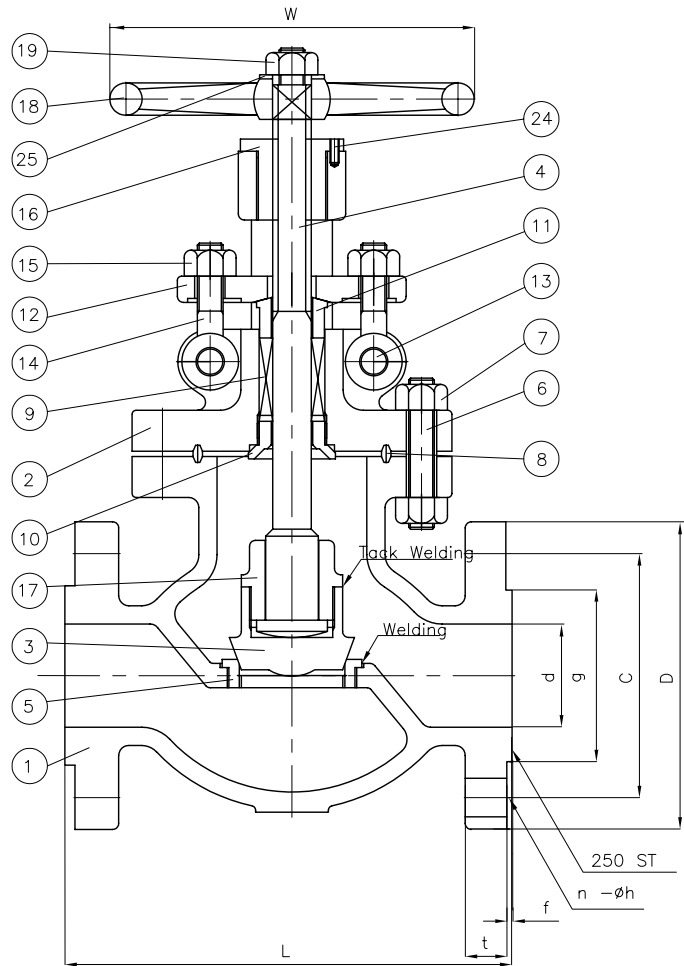

BILL OF MATERIALS				
NO.	PART NAME	MATERIALS	Q'TY	
1	BODY	A216Gr WCB	1	
2	BONNET	A216Gr WCB	1	
3	DISC	6" & BELOW	A217Gr CA15	1
		8" & OVER	A216Gr WCB W/13Cr FACED	
4	STEM	A479Gr 410	1	
5	SEAT RING	A105 H/F W/CO-Cr A	1	
6	BONNET BOLT	A193Gr B7	1SET	
7	BONNET NUT	A194Gr 2H	1SET	
8	GASKET	P#1500	1	
9	PACKING	P#6610+P#6528	1SET	
10	BACK SEAT	A479Gr 410	1	
11	GLAND RING	A479Gr 410	1	
12	GLAND FLANGE	A105 or WCB	1	
13	HINGE PIN	A105 or 410	2	
14	GLAND BOLT	A307Gr B	2	
15	GLAND NUT	A307Gr B	2	
16	BONNET BUSH	A439Gr D2C	1	
17	DISC NUT	A217Gr CA15	1	
18	HAND WHEEL	A197	1	
19	HANDLE NUT	A307Gr B	1	
24	SET SCREW	STEEL	1	
25	WASHER	STEEL	1	

UNIT: INCH

SIZE	d	L	D	C	g	t	f	n-øh	H	w
2.00	2.00	11.50	6.50	5.00	3.62	1.00	0.250	8-0.75	17.59	7.80
2.50	2.50	13.00	7.50	5.875	4.12	1.12	0.250	8-0.87	18.98	8.10
3.00	3.00	14.00	8.25	6.625	5.00	1.25	0.250	8-0.87	20.18	10.00
4.00	4.00	17.00	10.75	8.500	6.25	1.50	0.250	8-1.00	22.32	12.40
5.00	5.00	20.00	13.00	10.50	7.32	1.75	0.250	8-1.12	29.64	12.40
6.00	6.00	22.00	14.00	11.50	8.50	1.88	0.250	12-1.12	31.50	15.75
8.00	7.88	26.00	16.50	13.75	10.63	2.19	0.250	12-1.25	35.35	17.72
10.00	9.75	31.00	20.00	17.00	12.75	2.50	0.250	16-1.37	49.33	17.72
12.00	11.75	33.00	22.00	19.25	15.00	2.62	0.250	20-1.37	58.07	17.72

MARKING SYSTEM	MSS-SP-25	INSPECTION & TEST: API 598
DIM. OF FLANGE	ANSI B16.5	SHELL HYDRO 2225PSI
FACE TO FACE	ANSI B16.10	SEAT AIR 80PSI
WALL THICKNESS	API 600	BACK SEAT HYDRO 1650PSI
OVERALL	API 600, ANSI B16.34	

△					
△		RECHECKED DIM			
△		ISSUED FOR PROPOSAL			
NO.	DATE	DESCRIPTION	PRP'D	REV'D	APP'D
TITLE					
CAST STEEL GLOBE VALVE CLASS 600 B, B R, F					
SCALE	Fig #	DRAWING NO.		REV.	01
NONE	602F-2	60GL060129			