

Wm. E. Williams No. 90W2 Class 900 BW OS&Y Gate Valve ASTM A 216 WCB (API Trim 8)

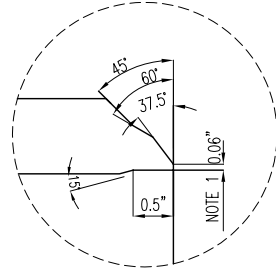
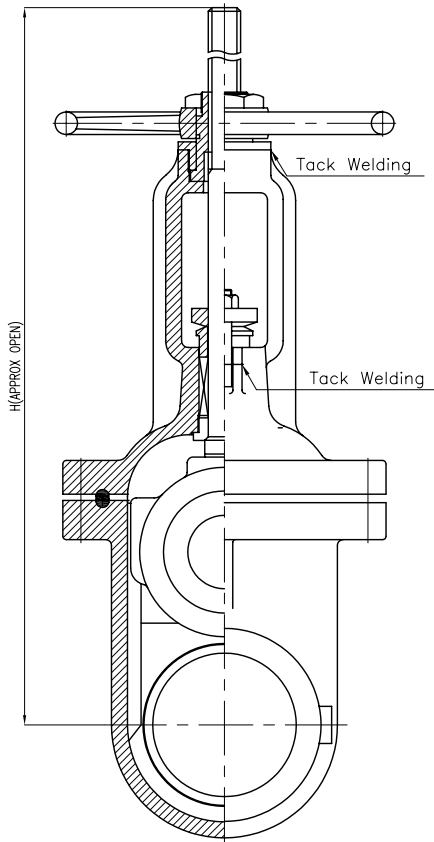
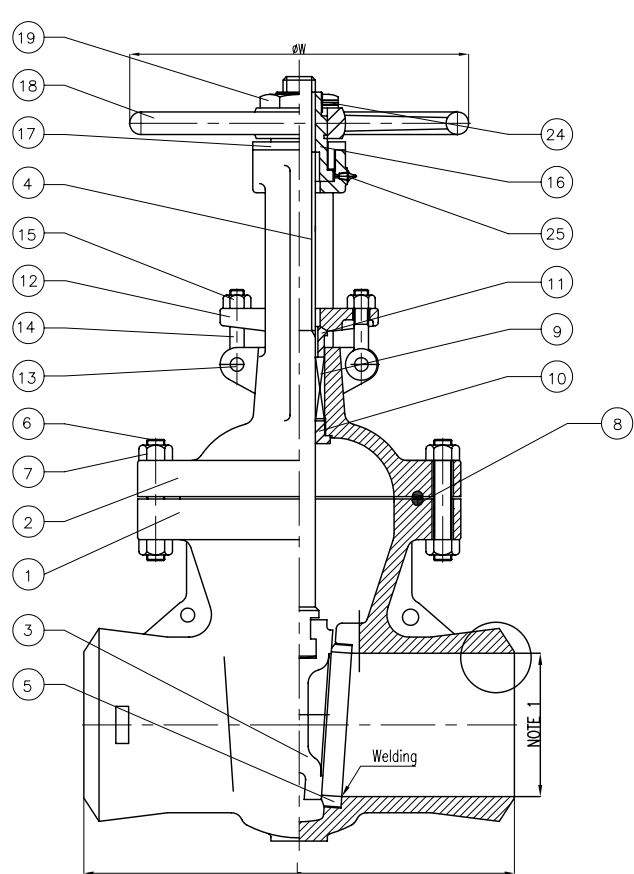

BUTTWELDING END

BILL OF MATERIALS			
NO.	PART NAME	MATERIALS	Q'TY
1	BODY	A216Gr WCB	1
2	BONNET	A216Gr WCB	1
3	DISC	6" & BELOW 8" & OVER A216Gr CA15 A216Gr WCB With 13Cr Welding	1
4	STEM	A479Gr 410	1
5	SEAT RING	A105 With STELLITE Welding	2
6	BONNET BOLT	A193Gr B7	1SET
7	BONNET NUT	A194Gr 2H	1SET
8	GASKET	LOW CARBON STEEL	1
9	PACKING	P#6610+P#6527	1SET
10	BACK SEAT	A479Gr 410	1
11	GLAND RING	A479Gr 410	1
12	GLAND FLANGE	A105 or WCB	1
13	HINGE PIN	A105	2
14	GLAND BOLT	A307Gr B	2
15	GLAND NUT	A307Gr B	2
16	YOKE SLEEVE	A439Gr D2C	1
17	SLEEVE NUT	A307 or WCB	1
18	HAND WHEEL	A197	1
19	HANDLE NUT	A307 or WCB	1
24	SET SCREW	STEEL	1
25	GREASE NIPPLE	STEEL	1

NOTE:
 1. SPECIFY PIPE SCHEDULE No. REQUIRED.
 2. TRIM #2, (API #8), OTHER TRIMS AVAILABLE

UNIT: INCH

SIZE	d	L	H	W
2.00	1.88	14.50	21.38	10.25
3.00	2.88	15.00	25.91	11.82
4.00	3.88	18.00	32.09	14.00
6.00	5.75	24.00	40.71	22.00
8.00	7.50	29.00	54.72	23.62
10.00	9.38	33.00	65.75	25.62
12.00	11.12	38.00	72.83	25.62
14.00	12.25	40.50	74.96	25.62
16.00	14.00	44.50	79.92	25.62
18.00	15.75	48.00	87.20	27.56
20.00	17.50	52.00	108.85	27.95
24.00	21.00	61.00	122.63	27.95

NO.	DATE	DESCRIPTION	PRP'D	REV'D	APP'D	MARKING SYSTEM	MSS-SP-25	INSPECTION & TEST: API 598
						BUTTWELDING	ANSI B16.25	SHELL HYDRO 3350 PSIG
						FACE TO FACE	ANSI B16.10	SEAT HYDRO 2450 PSIG
						WALL THICKNESS	API 600	AIR 80 PSIG
						DESIGNED	API 600	SCALE NONE

WILLIAMS
VALVE CORPORATION

TITLE CAST STEEL GATE VALVE
OS&Y BUTTWELD END

CLASS 900 LB		MATERIAL: WCB	
SIZE	Fig #	DRAWING NO.	REV.
2"-24"	90W-2	60GA060094	01