

Wm. E. Williams No. 150W2 Class 1500 BW OS&Y Gate Valve ASTM A 216 WCB (API Trim 8)

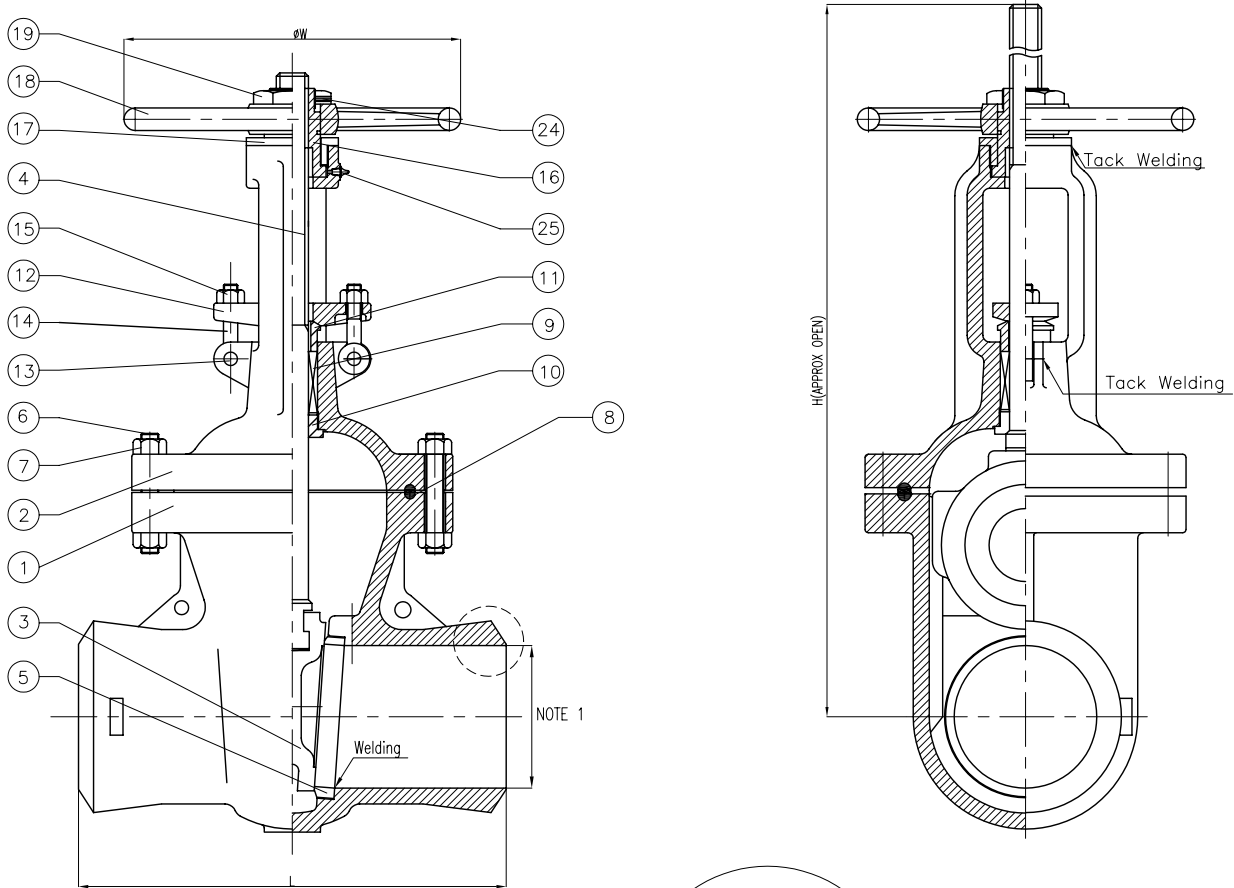

BILL OF MATERIALS				
NO.	PART NAME	MATERIALS	Q'TY	
1	BODY	A216Gr WCB	1	
2	BONNET	A216Gr WCB	1	
3	DISC	6" & BELOW 8" & OVER	A216Gr CA15 A216Gr WCB With 13Cr Welding	1
4	STEM	A479Gr 410	1	
5	SEAT RING	A105 With STELLITE Welding	2	
6	BONNET BOLT	A193Gr B7	1SET	
7	BONNET NUT	A194Gr 2H	1SET	
8	GASKET	LOW CARBON STEEL	1	
9	PACKING	P#6610+P#6527	1SET	
10	BACK SEAT	A479Gr 410	1	
11	GLAND RING	A479Gr 410	1	
12	GLAND FLANGE	A105 or WCB	1	
13	HINGE PIN	A105	2	
14	GLAND BOLT	A307Gr B	2	
15	GLAND NUT	A307Gr B	2	
16	YOKE SLEEVE	A439Gr D2C	1	
17	SLEEVE NUT	A307 or WCB	1	
18	HAND WHEEL	A197	1	
19	HANDLE NUT	A307 or WCB	1	
24	SET SCREW	STEEL	1	
25	GREASE NIPPLE	STEEL	1	

NOTE:
 1. SPECIFY PIPE SCHEDULE No. REQUIRED.
 2. TRIM #2, (API #8), OTHER TRIMS AVAILABLE

UNIT: INCH

SIZE	d	L	H	W
2.00	1.88	14.50	22.40	11.81
3.00	2.75	16.50	30.31	15.75
4.00	3.62	21.00	32.01	17.72
6.00	5.38	27.75	46.38	19.69
8.00	7.00	32.00	51.85	17.72
10.00	8.75	39.00	66.61	22.05
12.00	10.38	44.50	82.68	27.95
14.00	11.38	49.50	86.02	27.95
16.00	13.00	54.50	95.67	27.95
18.00	14.62	60.50	107.9	31.50
20.00	16.38	65.00	121.5	31.50
24.00	19.62	76.50	146.1	31.50

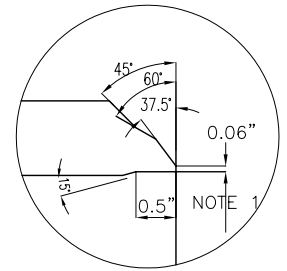

BUTTWELDING END

 	MARKING SYSTEM	MSS-SP-25	INSPECTION & TEST: API 598						
	BUTTWELDING	ANSI B16.25	SHELL	HYDRO	5575 PSIG				
	FACE TO FACE	ANSI B16.10	SEAT	HYDRO	4080 PSIG				
	WALL THICKNESS	API 600		AIR	80 PSIG				
NO.	DATE	DESCRIPTION	PRP'D	REV'D	APP'D	DESIGNED	API 600	SCALE	NONE

WILLIAMS
 VALVE CORPORATION

TITLE CAST STEEL GATE VALVE
OS&Y BUTTWELD END

CLASS 1500 LB		MATERIAL: WCB	
SIZE	Fig #	DRAWING NO.	REV.
2"-24"	150W-2	60GA060088	01