

BILL OF MATERIALS				
NO.	PART NAME	MATERIALS	Q'TY	NOTES
1	BODY	ASTM A105 N		
2	PISTON DISK	ASTM A276 420		
3	SPRING	17-4PH		
4	BONNET	ASTM A105 N		
5	DRIVE	ASTM A182 F304		
6	NAME PLATE	AL		

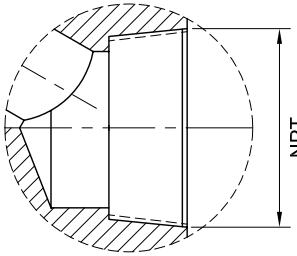

Detail "A"
SCREWED ENDS (NPT)
TO ANSI/ASME B1.20.1

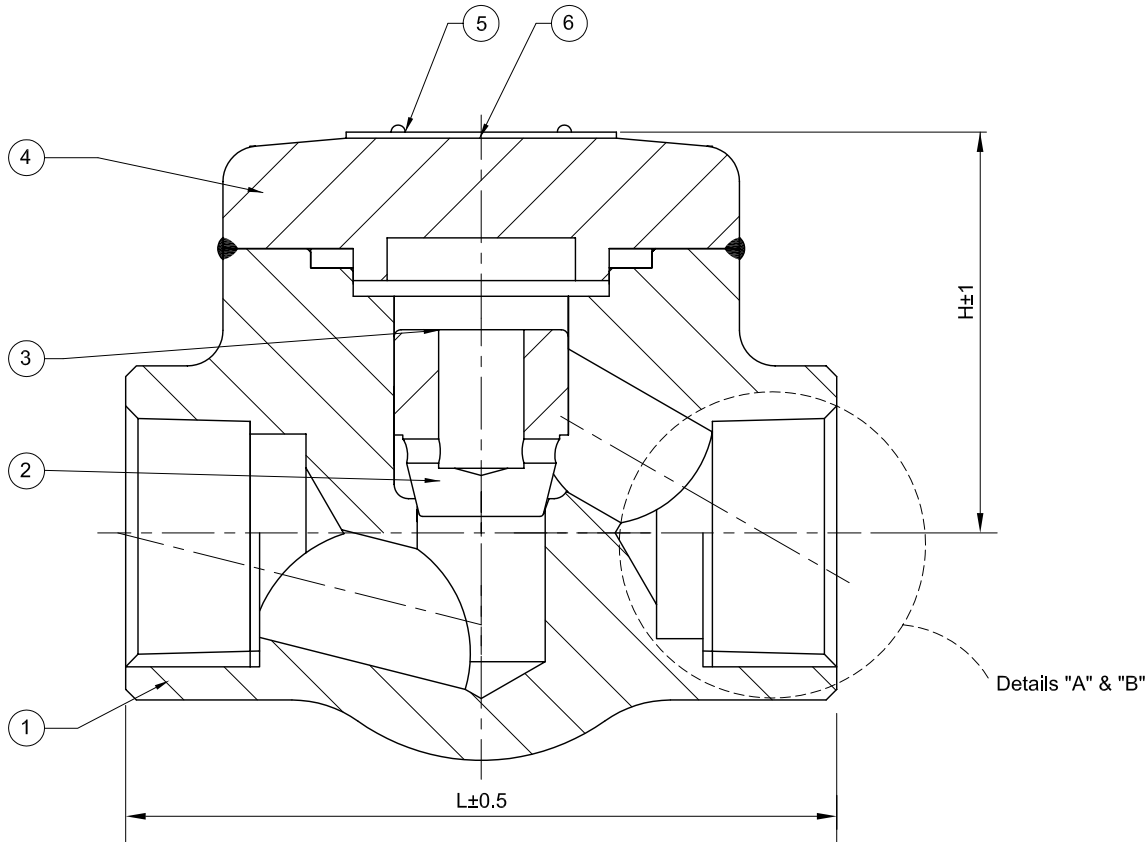
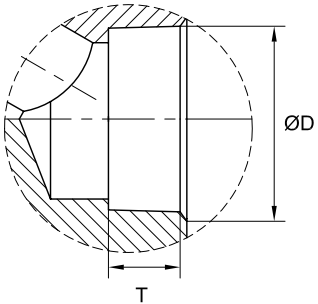

Detail "B"
SOCKET WELD ENDS
TO ASME B16.11

UNITS: mm

SIZE NPT	L	ØD	H	T
1/2	111	21.8	79	9.6
3/4	120	27.1	97	12.7
1	152	33.8	104	12.7
1 1/4	172	42.6	120	12.7
1 1/2	200	48.7	139	12.7
2	200	61.2	215	15.7

WILLIAM E. WWW.WILLIAMSVALVE.COM



WILLIAMS
VALVE CORPORATION

38-52 REVIEW AVENUE
LONG ISLAND CITY, NY 11101
TEL: 718-392-1660
FAX: 718-729-5105

TITLE: FORGED STEEL WELDED BONNET PISTON CHECK VALVE - CLASS 1500		
MATERIAL: A105N	UNITS: mm	
CLASS: 1500	DATE: 5/18/06	SCALE: N.T.S.
SIZE: 1/2" - 2"	FIG. No.: F1501LSW-2	
DRAWN BY: J.G.	DWG No.: 38PCK060071	
CHK'D & APR'D BY: R.S.		